

D2, D3 (Series 2000) DAMPER ACCESSORIES

INSTALLATION INSTRUCTIONS

INSTALLING SINGLE-SECTION WIDE DAMPERS

For Dampers Less Than 24 in. (61 mm) in Height (See Fig. 1)

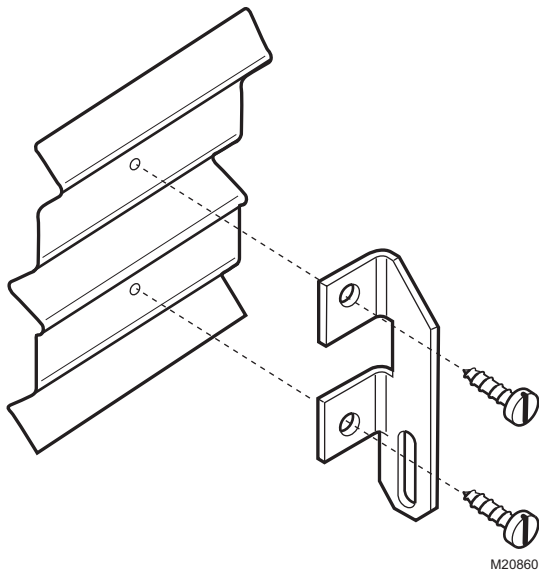

Fig. 1. Attaching 32007205-002 Blade Drive Lever.

Parts Included in 32007205-002:

Qty	Description
1	Right-angle Lever
2	#1/4-20 x 1/2 TCS Fasteners

For Dampers Greater Than or Equal to 24 in. (61 mm) in Height (See Fig. 2)

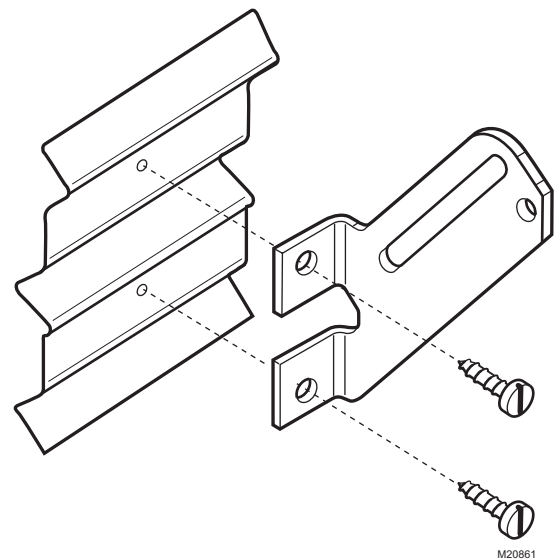

Fig. 2. Attaching 3207205-003 Blade Drive Lever.

Parts Included 32007205-003:

Qty	Description
1	45° Drive Lever
2	#1/4-20 x 1/2 TCS Fasteners



CONNECTING MULTI-SECTION WIDE DAMPERS WITH NO JACKSHAFT

For Dampers Less than 24 in. (61 mm) High

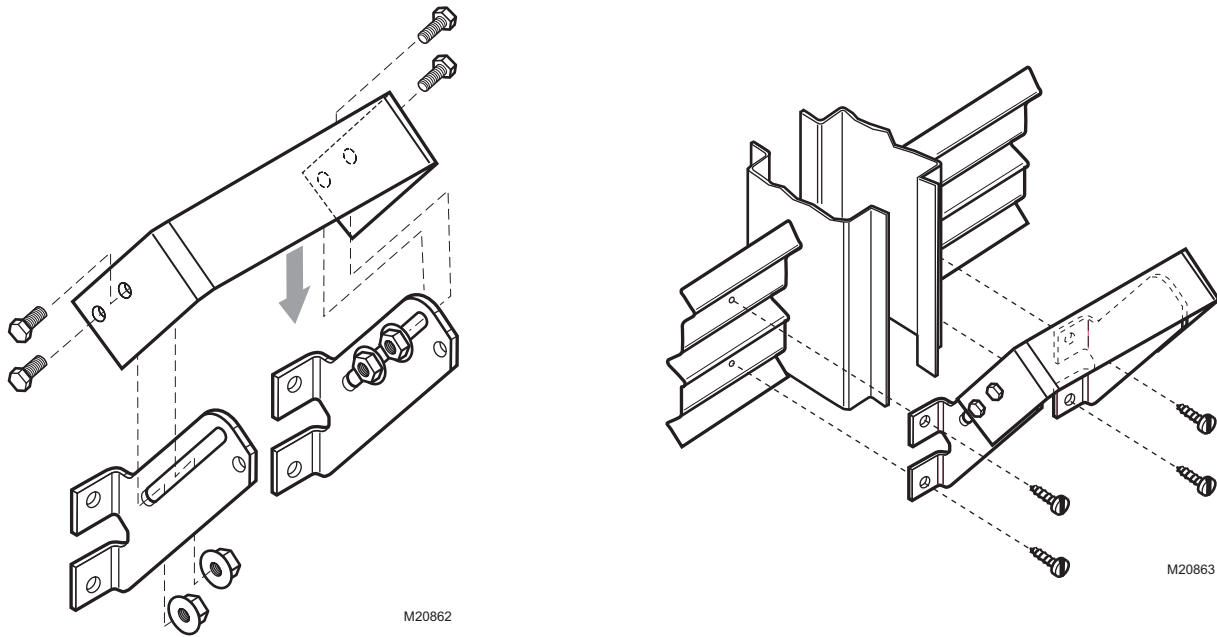

Fig. 3. Attaching 32007205-007 Jumper Bracket to blade drive levers and dampers.

Parts Included in 32007205-007:

Qty	Description
1	Lever Linkage
4	#1/4-20 x x1/2 Bolts
4	#1/4-20 Nuts
2	45° Drive Lever
4	#14 x 3/4 HWH Tek Fasteners

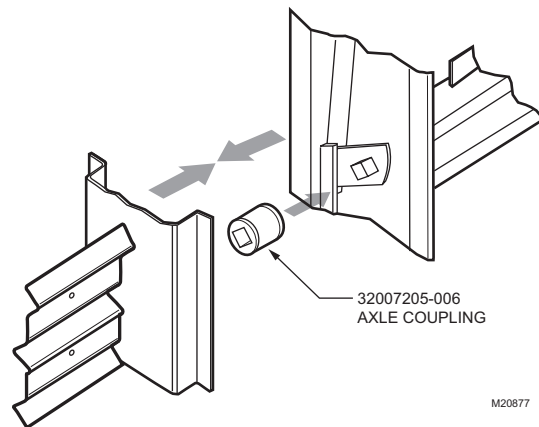

Fig. 4. 32007205-006 Axle Coupling.

Parts included in 32007205-006:

Qty	Description
1	Coupling

SHAFT EXTENSIONS

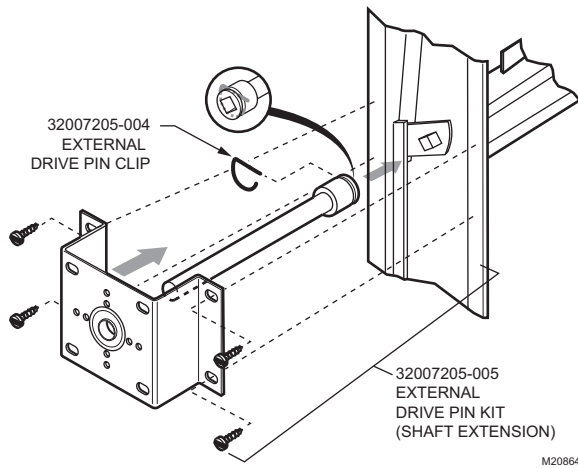

Fig. 5. Attaching 32007205-005 Shaft Extension.

Parts Included in 32007205-005:

Qty	Description
1	Drive Pin Clip (32007205-004)
1	Shaft Extension
1	Mounting Bracket

For the 32007205-005 and -001:
 — The installer supplies the screws.
 — #14 x 3/4 HWH Tek Fasteners are recommended.

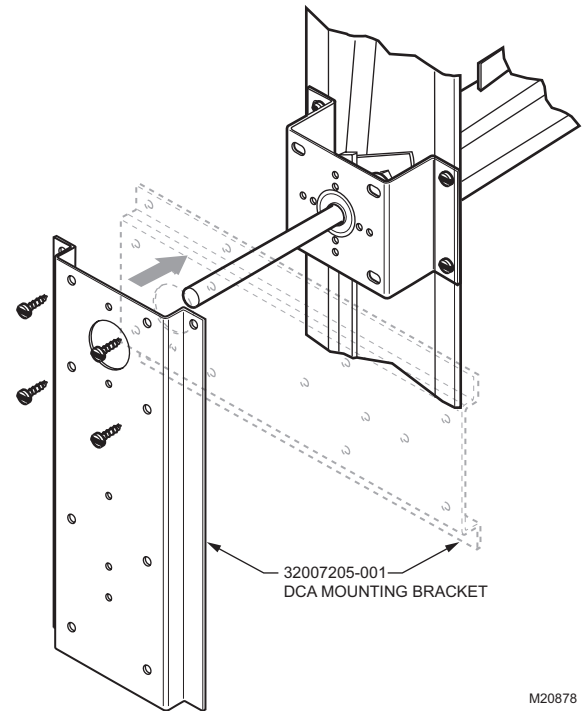

Fig. 6. Attaching 32007205-001 DCA Mounting Bracket.

Parts Included in 32007205-001:

Qty	Description
1	Mounting Bracket

By using this Honeywell literature, you agree that Honeywell will have no liability for any damages arising out of your use or modification to, the literature. You will defend and indemnify Honeywell, its affiliates and subsidiaries, from and against any liability, cost, or damages, including attorneys' fees, arising out of, or resulting from, any modification to the literature by you.

Automation and Control Solutions

Honeywell International Inc.

Honeywell Limited-Honeywell Limitée

Honeywell

